

TRANSIT • VERTICAL SUBWAY POSTERS

PRODUCTION SPECIFICATIONS & FINISHING REQUIREMENTS

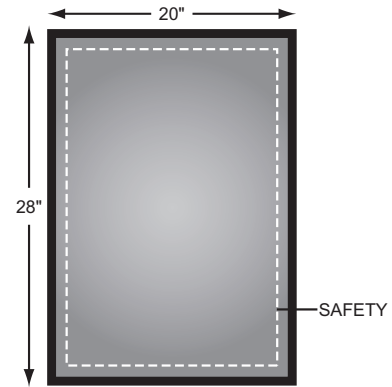

DIMENSIONS	TRIM (W x H)	VISIBLE OPENING * (W x H)	SAFETY (W x H)
	20" x 28"	18.25" x 26.25"	17.5" x 25.5"

INTERMEDIATE FILE SIZE	TRIM (W x H)	VISIBLE OPENING (W x H)	SAFETY (W x H)	BLEED (W x H)
	20" x 28"	18.25" x 26.25"	17.5" x 25.5"	20.5" x 28.5"

SUPPLYING FILES FOR PRODUCTION

Layout	Supply artwork at ACTUAL SIZE. Always provide crop marks & bleed in your file.
Templates	Digital templates are available to assist you in preparing your artwork. Please contact your CBS OUTDOOR Production Account Manager for production templates.
Software	MAC: QuarkXpress 6.0; InDesign CS; Illustrator CS; Photoshop CS PC: QuarkXpress 4.1; Illustrator 8.0
Transfer Media	ZIP, CD, DVD, FTP. Disks will be returned by request only. Please contact your CBS OUTDOOR Production Account Manager for current FTP specifications.
Images	300 DPI, CMYK, 100% at INTERMEDIATE FILE SIZE. Convert RGB files to CMYK. Accepted image types: TIFF, EPS, Scitex CT. JPEGs not accepted. Do not exceed a file size of 400mb or fall below 40 mb.
Type & Fonts	Minimum recommended type size for critical copy: 72 pt (1" at ACTUAL SIZE) Include printer & screen fonts with artwork or convert fonts to outlines.
Colour	All production in CMYK unless otherwise indicated. Indicate PMS colours on proof.
Density	Maximum 280% density. Dots smaller than 5% may not be visible when printed due to blow out
UCR/GCR	UCR can be utilized in a background that would normally register as 3 solids plus black. GCR is <u>not</u> to be utilized.
Support	Support solid (rich) blacks with 40% C or M, if required.
Proofs	All files must be accompanied by a hard-copy proof. Provide professional quality colour proof for colour accuracy.

* Frame sizes vary in thickness due to many generations of framing systems in TTC subways and stairwells. These Visible Opening and Safety dimensions account for all frame sizes and openings. Please notify your CBS OUTDOOR Account Manager if your creative requires special attention where framing is concerned.

SUBSTRATE CHANGE • AUGUST 1, 2007
 All *Vertical Subway Poster* media contracts signed after July 31, 2007, must be produced on **Hydros Board** fire-retardant stock and must be produced through the CBS Outdoor Production Group.

SUPPLY CHANGE • NOVEMBER 15, 2007
Hydros Board will be available to all printers after November 15, 2007.
 See **PRINTING & FINISHING REQUIREMENTS** for more details.

TRANSIT • VERTICAL SUBWAY POSTERS

PRODUCTION SPECIFICATIONS & FINISHING REQUIREMENTS

PAGE 2 OF 2

CBS OUTDOOR PRODUCTION GROUP

CBS OUTDOOR owns and operates a full-service in-house production facility in Toronto, and can provide production for every one of our products. Our dedicated staff of outdoor and production experts are committed to producing your outdoor right, on budget, and on time.

Please contact us for a production estimate for your next project!

PRINTING & FINISHING REQUIREMENTS

Production	Lithography or screen printing
Substrate	<ul style="list-style-type: none"> • 390gsm Aconda Hydros Board <p>All contracts signed after July 31, 2007 must be printed on 390gsm Aconda Hydros Board fire-retardant stock. <i>Please see HYDROS DISTRIBUTION & PRODUCTION, below.</i></p> <p>Hydros Board is watermarked with a trademarked logo on the reverse side. <i>No other materials will be accepted for posting by CBS OUTDOOR TRANSIT OPERATIONS.</i></p> <p>VERTICAL SUBWAY POSTERS posting only on Subway Station walls may be supplied on 20 pt. Starcote/Printcote</p>
Take-One Pads	Please contact CBS OUTDOOR TRANSIT OPERATIONS for specifications if your product requires TAKE-ONE PADS.
Overage	20% overage is required depending on poster re-use, creative design, or the length of the campaign

HYDROS DISTRIBUTION & PRODUCTION

In Canada, **Aconda Hydros Board** is distributed through **Spicers** (<http://www.spicers.ca>). This substrate will be available to all suppliers after November 15, 2007. In the interim, all VERTICAL SUBWAY POSTER production must be supplied by the CBS OUTDOOR PRODUCTION GROUP.

Should you have any questions regarding the above information, please feel free to contact Laurie Kelly, Director, Production Group at (416) 521-6517 or at lkelly@cbsoutdoor.ca

The quality of production supplied to CBS OUTDOOR is the responsibility of the advertiser.

CBS OUTDOOR proactively maintains the faces on our structures. Should the production supplied not meet the minimum standards outlined or not remain posted when using standard procedures, the advertiser/agency is responsible for:

- additional posting costs incurred to maintain the face
- all contracted space should CBS OUTDOOR be unable to post the product