

TRANSIT SHELTERS

PRODUCTION SPECIFICATIONS & FINISHING REQUIREMENTS

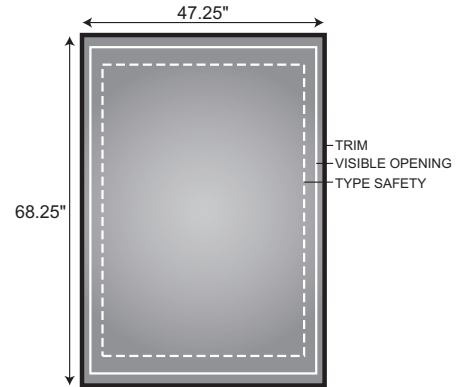

DIMENSIONS	TRIM (W x H)	VISIBLE OPENING (W x H)	SAFETY (W x H)
------------	-----------------	----------------------------	-------------------

	47.25" x 68.25"	45" x 66.25"	42.5" x 64.6875"
--	-----------------	--------------	------------------

INTERMEDIATE FILE SIZE	TRIM (W x H)	VISIBLE OPENING (W x H)	SAFETY (W x H)	BLEED (W x H)
------------------------	-----------------	----------------------------	-------------------	------------------

	17.18" x 24.818"	16.36" x 24.09"	15.45" x 23.52"	17.68" x 25.318"
--	------------------	-----------------	-----------------	------------------

SUPPLYING FILES FOR PRODUCTION

Layout	Supply artwork at INTERMEDIATE FILE SIZE, not actual size. Files will be digitally enlarged to final size during the production process. Always provide crop marks & bleed in your file.
Templates	Digital templates are available to assist you in preparing your artwork. Please contact your CBS OUTDOOR Production Account Manager for production templates.
Software	MAC: QuarkXpress 6.0; InDesign CS; Illustrator CS; Photoshop CS PC: QuarkXpress 4.1; Illustrator 8.0
Transfer Media	ZIP, CD, DVD, FTP. Disks will be returned by request only. Please contact your CBS OUTDOOR Production Account Manager for current FTP specifications.
Images	350 DPI, CMYK , 100% at INTERMEDIATE FILE SIZE. Convert RGB files to CMYK. Accepted image types: TIFF, EPS, Scitex CT. JPEGs not accepted. Do not exceed a file size of 400mb or fall below 40 mb.
Type & Fonts	Minimum recommended type size for critical copy: 104 pt (4" at ACTUAL SIZE) Include printer & screen fonts with artwork or convert fonts to outlines.
Colour	All production in CMYK unless otherwise indicated. Indicate PMS colours on proof.
Density	Maximum 280% density. Dots smaller than 5% may not be visible when printed due to blow out
UCR/GCR	UCR can be utilized in a background that would normally register as 3 solids plus black. GCR is <u>not</u> to be utilized.
Support	Support solid (rich) blacks with 40% C or M, if required.
Proofs	All files must be accompanied by a hard-copy proof. Provide professional quality colour proof for colour accuracy.

TRANSIT SHELTERS

PRODUCTION SPECIFICATIONS & FINISHING REQUIREMENTS

PAGE 2 OF 2

CBS OUTDOOR PRODUCTION GROUP

CBS OUTDOOR owns and operates a full-service in-house production facility in Toronto, and can provide production for every one of our products. Our dedicated staff of outdoor and production experts are committed to producing your outdoor right, on budget, and on time.

Please contact us for a production estimate for your next project!

PRINTING & FINISHING REQUIREMENTS

Production	Lithography, Screen-print or Digital Printing
Substrate	<p>7 pt. Coated Translucent Bristol for lithography or screen-print</p> <ul style="list-style-type: none"> Resistant to shrinking, stretching, fading and humidity 7 pt. Bristol may wrinkle in humid or wet weather, but will usually smooth out when dry CBS OUTDOOR does not accept Transit Shelters Posters printed on styrene <p>0.85 Opaline (with lamination) for digital production</p>
Lamination	<ul style="list-style-type: none"> 10ml total lamination (5ml each front & back) may be used for lighter stocks for longevity Laminated Transit Shelter Posters are NOT accepted in Vancouver
Colour	Transit Shelter Posters should be printed both front and back to ensure that colour density is maintained when posters are backlit at night.
Ink Characteristics	Inks should contain UV Inhibitors to prevent fading over long periods of time.
Shipping	<ul style="list-style-type: none"> Posters should be rolled in cardboard tubes (no boxes, skids or paper wrap) Maximum 35 posters per tube Advertiser name, design name and first posting date should be clearly marked on the outside of each tube Indicate CBS OUTDOOR MEDIA CONTRACT number on package.

The quality of production supplied to CBS OUTDOOR is the responsibility of the advertiser.

CBS OUTDOOR proactively maintains the faces on our structures. Should the production supplied not meet the minimum standards outlined or not remain posted when using standard procedures, the advertiser/agency is responsible for:

- additional posting costs incurred to maintain the face
- all contracted space should CBS OUTDOOR be unable to post the product